



SANY
我们的深度决定世界的高度
Our drilling depth determines the height of the world

SR155

SR155

2020 Rotary Drilling Rig

**Flexible
Easy to operate**



Follow us on Wechat and contact us
Support hotline. 4006 09 8318
Email: crd@sany.com.cn

- Max. drilling diameter 1.5m
- Max. drilling depth 56/44m
- Rated output torque 155kN·m
- Engine power 147kW/2100rpm

Main performances	Unit	Parameter	Remark
Pile			
Max. drilling diameter	mm	1500	
Max. drilling depth	m	56/44	①
Rotary drive			
Rated output torque	kN · m	155	
Rotation Speed	rpm	5~35	
Crowd system			
Crowd force	kN	155	
Line pull	kN	160	
Stroke	mm	4200	
Main winch			
Lifting capacity	kN	160	
Wire rope diameter	mm	26	
Max. line speed	m/min	80	
Auxiliary winch			
Lifting capacity	kN	60	
Wire rope diameter	mm	14	
Max. line speed	m/min	75	
Mast inclination			
Forward/backward	°	5/90	
Lateral	°	±3	
Main Chassis			
Base engine	/	D06FR	Mitsubishi
Engine power	kW/rpm	147/2100	
Emission regulation	/	COM III	
Engine displacement	L	6.373	
Chassis length	mm	5975	
Extension width	mm	4100	
Track shoe width	mm	700	
Swing radius	mm	3715	
Overall machine			
Overall height	mm	18590	
Operating weight	t	48	
Transport width	mm	3140	
Transport height	mm	3265	

①: friction kelly depth / interlocking kelly depth

Kelly bar	Weight(Kg)	Depth(m)	Option
Inter-locking kelly	Φ377 × 4 × 11	6100	40
	Φ377 × 4 × 12	6600	44
Friction kelly	Φ377 × 4 × 12	6100	44
	Φ377 × 5 × 12	5800	56

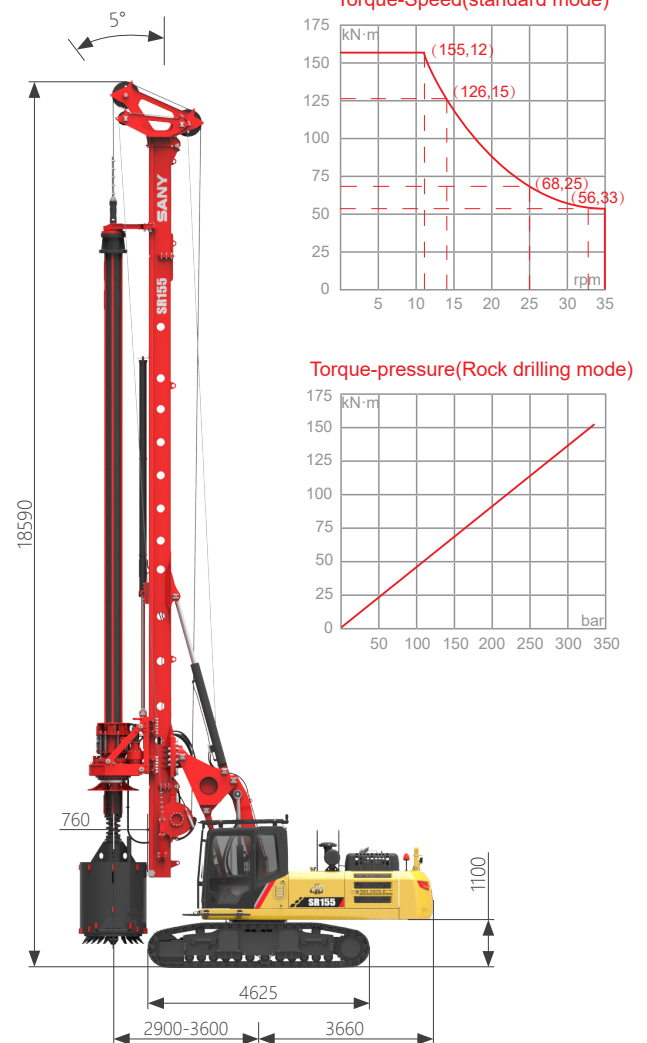
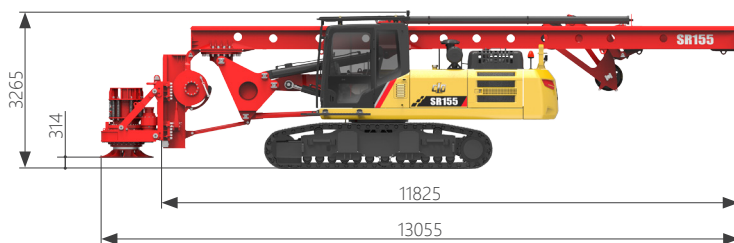

High efficiency and flexibility: Suitable for the construction of small and medium-sized soil layer boreholes. High main winch lifting speed and boreholes vertically, flexible operation, working efficiency higher than similar models of competitor by 15%.

Economical fuel saving: Using power optimization control technology, real-time adjustment of power distribution, quick response, high fuel efficiency, comprehensive energy saving by 10% to 15%.

High reliability: The mast adopts box structure with strong resistance to torsion and fatigue; sixth generation kellybar adopting upgraded material and strengthened block ring, the overall strength increased by 25% with high drilling ability in strongly weathered rock layer.

Convenient transportation: The whole machine size is small, only 48T in weight, barrier free in city transportation and meet height limit.

Intelligent upgrade: 10-inch HD touch screen, fast response and more convenient operation.