

SANY[®]

SSP90C-8 MULTIFUNCTIONAL PAVER

SSP90C-8 多功能摊铺机

Heavy thickness pavement No.1 in China.
大厚度摊铺 唯我独尊



STRONG POWER

- ◆ The power can satisfy the paver's demands under different working conditions;
- ◆ Low noise, less oil consumption and better machine reliability under economic gear mode.

EFFICIENCY

- ◆ It is able to ensure over 1,000 t/h paving capacity under all conditions, which is peerless in the industry.
- ◆ With 50cm paving thickness, it can realize the paving and molding of two layers of stable soils in one time, which can improve working efficiency by 50%.
- ◆ 2 persons can finish assembling 10 m screed within 2.5 hr.
- ◆ Adopt self-developed SYMC control system to achieve remote technical support and equipment management.
- ◆ The spiral feed divider can realize one-key overall lifting to improve equipment operation convenience and work adaptability significantly.

ECONOMICAL

- ◆ The conveying channel is made of thickened wearing-resistant steel plate and the service life of wearing-resistant parts is increased by 30%.
- ◆ Strong continuous working capacity to ensure the non-stop working requirements under 50 °C temperature.

动力强劲

- ◆ 动力充分满足摊铺机各种工况下动力需求。
- ◆ 经济档转速下噪音更低，油耗更少，机器可靠性得到大幅提升。

经济

- ◆ 输料通道采用增厚耐磨钢板制作，耐磨件寿命提升 30%。
- ◆ 连续工作能力强，确保 50 度高温环境连续不停机作业要求。

高效

- ◆ 任何工况，确保摊铺能力大于 1000t/h，行业内绝无仅有。
- ◆ 一次成型厚度达 50 厘米，可实现两层稳定土一次摊铺成型，提升工作效率 50%。
- ◆ 快速拼装熨平板，2 人可在 25 小时内完成 10 米熨平板拼装。
- ◆ 使用自主研发的 SYMC 控制系统，可实现远程技术支持和设备管理。
- ◆ 螺旋分料装置实现了一键整体提升，极大提高了设备的操作便捷性和工况适应能力。

TECHNICAL PARAMETER

技术参数

SSP90C-8 多功能摊铺机技术参数

Technical Parameters of SSP90C-8 Multifunctional Paver

型号 Model	SSP90C-8
最大理论生产能力 Paving Capacity(t/h)	900
最大摊铺宽度 Paving Width(m)	伸缩板 Hydraulic: 9.2
基本宽度 Basic Width(m)	伸缩板 Hydraulic: 3~5.7
最大摊铺厚度 Max. Paving Thickness(cm)	50
工作速度 Working Speed(m/min)	1~16
行驶速度 Travel Speed(km/h)	0~2.4
运输尺寸 Transport Size(mm)	伸缩板 Hydraulic: 7250×3210×3280
发动机品牌 Engine Brand	SANY
发动机型号 Engine Model	D07S3-245E0
额定功率 Rated Power of Engine(kW)	180
额定转速 Rated Speed of Engine(rpm)	2050
排放标准 Emission Standard	CHINA III
电控系统电压 Voltage of Electric System(V)	24
最大爬坡能力 Gradeability	≥20%
料斗容量 Hopper Capacity(m³)	8.5
加热方式 Heating Mode	电加热 Electric Heated
拱度调节范围 Camber Adjustment Range(%)	-1~3
振捣数量 Tamps	1
振捣振幅 Amplitude of Tamp(mm)	0/2/4/6/8
振捣频率 Frequency of Tamp(Hz)	0~25
振动频率 Frequency of Oscillation(Hz)	0~50

SSP90C-8 多功能摊铺机尺寸参数

Dimensions of SSP90C-8 Multifunctional Paver

型号 Model	SSP90C-8
A(mm)	4022
B(mm)	3308
C(mm)	3278
D (°)	14
E (°)	12.5
F(mm)	2600
G(mm)	2040
I(mm)	3660
L(mm)	7197

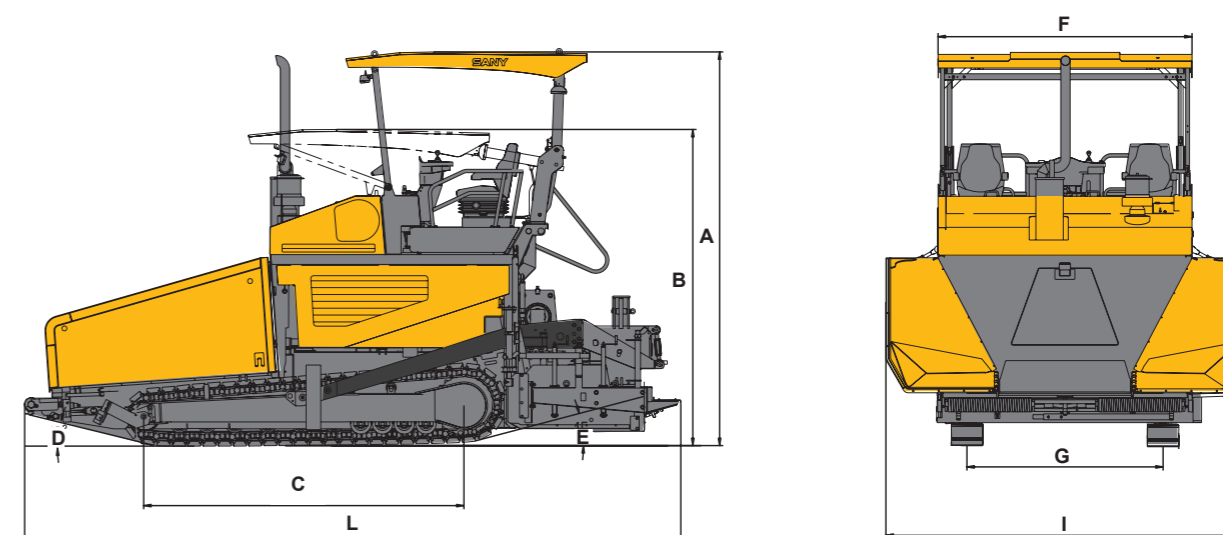

SANY HEAVY INDUSTRY CO., LTD.

SANY Industry Town, Changsha Economic and Technological Development Zone,
Hunan Province, China
Service Line: +86 4006 098 318 E-mail: crd@sany.com.cn

SANY[®]
QUALITY CHANGES THE WORLD.